

Saw chain grinder Model X1

Manual



Contents

Foreword	1
General	2
Safety Instructions	3
Technical data	4
Compressed air	4
Overview	5
Grinder	6
Grinding section	7
Operating panel	8
Machine use	9
Before grinding	9
Working principle	9
Compressed air:	10
Drive link thickness	11
Setting the pitch	13
Feed setting	14
Grinding depth adjustment	15
Setting the grinding angle α	16
Main screen	17
Main screen touch display	17
Initial page	17
Start page	18
Contact page	18
Grinding page	19
Grinding settings	20
Chain setting	23
Machine settings	25
Language setting	26
Alarm page	27
Alarm, grinding	27
Maintenance	28
Safety	28
Daily	28
Adjusting the air pressure	29

If necessary, check/clean compressed air	30
Cleaning machine	31
Changing the grinding wheel	32
Belt tensioning	33
Replacing the drive belt	34
Close-up images	35
Feeder unit linear control	35
Grinding wheel lifting cylinder	36
Swivel cylinder	37
Connections	37
Troubleshooting	38
Problem solving	38
The machine does not start	38
Motor guard triggered	38
Sensor arms do not rise/both sensor arms rise	38
Alarm from the frequency inverter	38

Foreword

Thank you for entrusting us to supply your company with an ANAB X1 chain grinder.

The purpose of the instruction manual is to provide basic and necessary knowledge concerning the functions and design of the machine.

The manual contains plenty of useful information you should know, even if you are familiar with grinders and their use.

Read the manual before putting the machine into operation, since correct care and handling are necessary to ensure that the chain grinder offers you optimal functionality and economy.

If you have any questions, kindly contact our Customer Service department or a sales representative, who will be happy to help.

In case of enquiries or if you would like to order spare parts, please specify the machine type, machine number and year of manufacture.

Year of manufacture:	
Machine type:	
Machine number:	
Delivery date:	
Checked by:	
Installation date:	
Signature:	
Remarks:	

Manufacturer: ANAB
 Åsbacksvägen 6
 SE-836 71 Ås
 SWEDEN
 Tel: +46 (0)63102058

E-mail: info@anab.nu
www.anab.nu

We reserve the right to change the technical specifications without prior notice.

Images may differ from your specific machine, depending on the machine model.

General

The ANAB X1 chain grinder is an automatic grinding machine for saw and machine chains. Working methods and adjustment options mean that just about any type of chain can be sharpened.

Automatic detection of the direction of the cutting teeth means that the grinding wheel is always in the correct position. The machine operates electro-pneumatically and the functions are controlled by a programmable control unit.

All electrical equipment is located in the lower part of the machine, where it is protected. The machine is designed for long-term and largely maintenance-free operation; only minor adjustments are required.

When servicing the machinery, only trained service personnel should be engaged.

The following settings should be made prior to grinding:

- Drive link thickness
- Pitch
- Grinding depth / Rider height
- Felling and tooth length
- Compressed air
- Number of cutting teeth
- Setting the grinding angle α .

Chain type	Grinding wheel
1/4"	3 mm grinding wheel
.325"	4 mm grinding wheel
3/8" low profile	4 mm grinding wheel
.404"	3 mm grinding wheel with smaller diameter
.404" Stihl Rmhs	5.5 mm grinding wheel

Safety Instructions



- Whenever any work is carried out on or near a machine in operation (e.g. when profiling a grinding wheel), protective clothing, protective gloves, and a full-face visor must be worn!
- Hearing protection must be worn in the vicinity of a machine in operation!
- Only use original ANAB-approved grinding wheels!
- Always check that the chains are undamaged before grinding (for example, damaged teeth or rivets)!
- Crooked chains must be discarded or straightened before grinding!
- Broken chains (cutting teeth) must be repaired before grinding!
- Heavily chipped/burred chains must always be discarded!
- Close the door before grinding!
- Always check before operation that the compressed air gauge shows the approved value! Risk of explosion if the pressure is too high.
- Always make sure that there is no damage to the electrical connection before starting the machine!
- The electrical connection must be earthed by a professional!
- In the event of an electrical malfunction, a licenced electrician must be called in!
- In the event of malfunction in other machine parts: Contact your service engineer or ANAB!
- Always make sure that there are no unauthorised persons in the vicinity of the machine during operation!
- If a warning sign is missing or damaged and no longer clearly legible, it must be replaced as soon as possible!

Technical data

Drive system: Electrical/pneumatic.

Control system: PLC based, fully automatic or manually step by step. Sensor for cutting teeth, always grinds in the correct direction.

Grinding angle α : 0-35°

Drive link thickness: Continuous adjustment 1.3–3.0 mm.

Chain types: Standard chains

Max. pitch: 1/4" to 20 mm (see *Bild 9* sida 13)

Grinding wheels: Special profile.

Electric motor: 0.37 kW frequency inverter.

Motor speed: Continuous adjustment with frequency inverter.

Display: 4,3"

Compressed air

Pressure: approx. 6 Bar.

Air requirement: min. 33 l/min.

— OBS —

The air should be separated from water after the main compressor

Connection: R 1/4"

Min. hose dimension: 10 mm internal.

Unit containing pressure regulator and shut-off valve included.

Overview

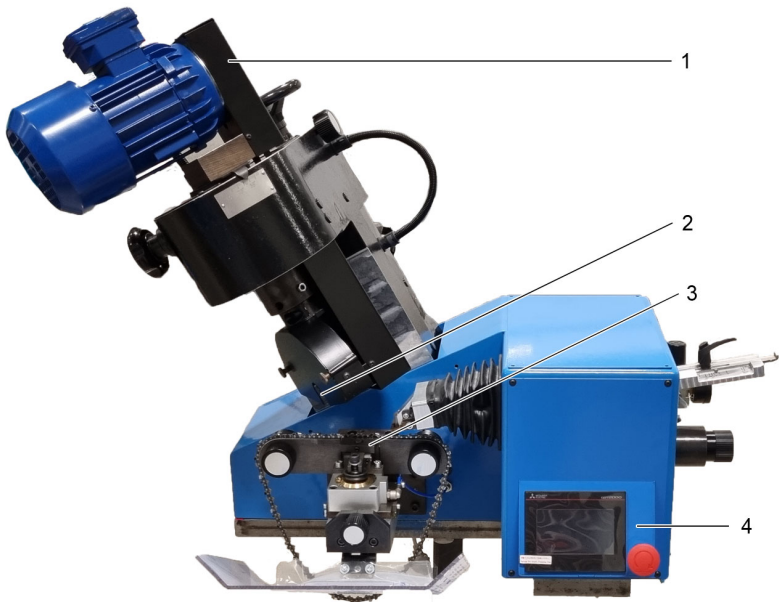

- 1 Grinder
- 2 Grinding wheel

- 3 Clamp
- 4 Control panel

Image 1. Machine overview

Grinder

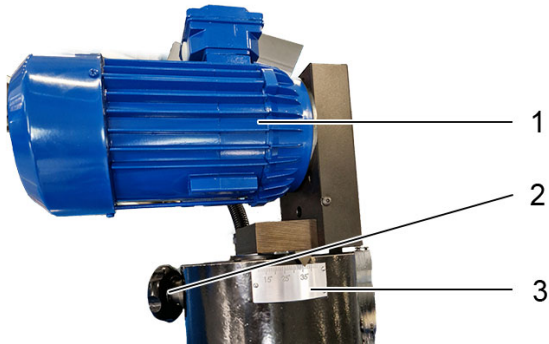

1 Motor belt drive

2 Knob, grinding angle α

3 Scale, grinding angle α

Image 2. Grinder

Grinding section

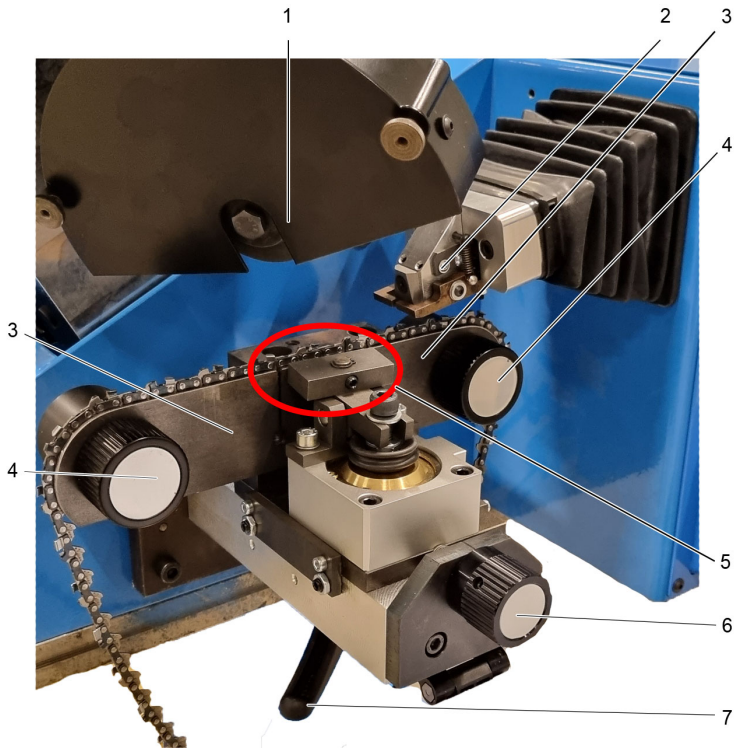

- | | | | |
|---|------------------|---|------------------------------|
| 1 | Grinding wheel | 5 | Chain rail plates |
| 2 | Clamping piece | 6 | Setting drive link thickness |
| 3 | Feeder | 7 | Locking knob, chain holder |
| 4 | Gap setting knob | | |

Image 3. Grinding section

Operating panel

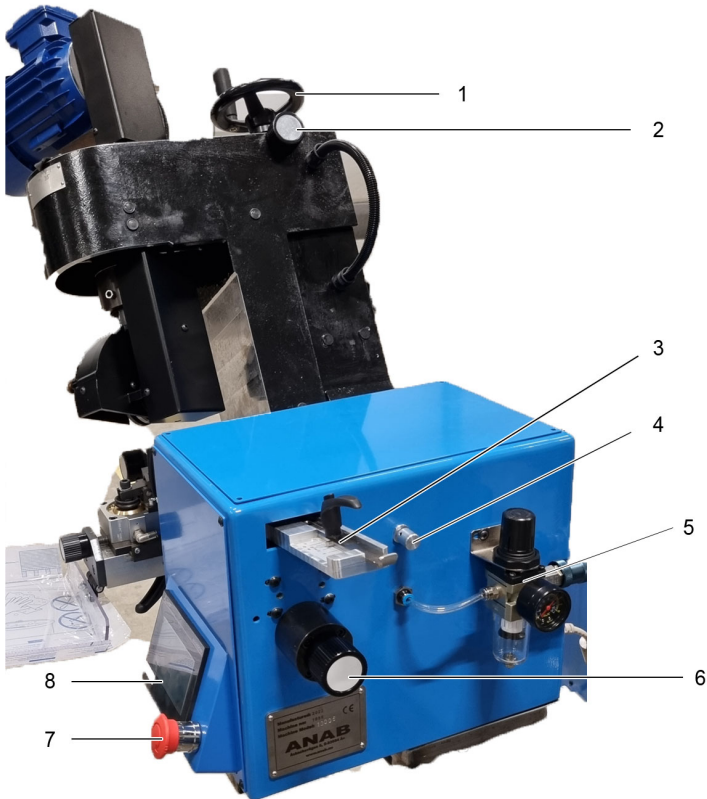

- | | | | |
|---|--------------------------------|---|-------------------------------|
| 1 | Setting grinding depth β | 5 | Air pressure gauger |
| 2 | Locking knob | 6 | Setting the grinding quantity |
| 3 | Scale for pitch | 7 | Emergency stop |
| 4 | Speed control grinder | 8 | Touch display |

Image 4. Operating panel

Machine use

Before grinding

In principle, it is possible to grind rigid, damaged or otherwise defective chains, but this is not appropriate for safety reasons.

Visually inspect the chains thoroughly before grinding, keep an eye out for cracking around the rivets in particular. Always check that the chains are undamaged before grinding (for example, damaged teeth or rivets)! Clean the chains and lubricate them before grinding for best results. Discard defective chains.

The following settings should be made prior to grinding:

- Drive link thickness
- Pitch
- Grinding depth / Rider height
- Felling and tooth length
- Compressed air
- Number of cutting teeth
- Setting the grinding angle α .

Common chain defects requiring the chain to be discarded:

- Rigid chains, poorly lubricated with cuts in the rivets.
- Deep chips that require heavy grinding.
- Bent teeth or links.
- Fatigue damage, cracking around the rivets.
- Abraded teeth (tooth length should not be less than 5-6 mm on machine chains).
- Uneven filing, noticeably different tooth lengths.
- Dry chains, loose rivets.
- Crooked chains must be discarded or straightened before grinding!
- Broken chains (cutting teeth) must be repaired before grinding!
- Heavily chipped/burred chains must always be discarded!

Working principle

When feeding the chain, the machine detects each saw tooth and detects whether there is an inner or outer cutting tooth in the grinding position. After this, the grinding wheel is turned and lowered for grinding.

Compressed air:

The compressed air should be turned off with the valve (See *Bild 5 Pos 2 Shutting off air*) when the machine is not in use.

Open the air valve slowly.

Set the air pressure with knob (See *Bild 5 Pos 1 Knob, pressure regulator*) to 6 bar on the pressure gauge.

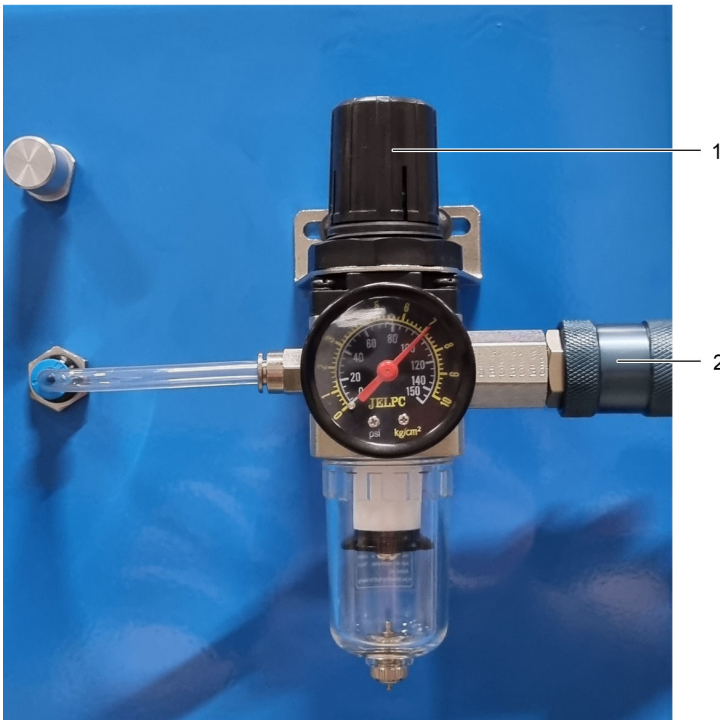

1 Knob, pressure regulator

2 Shutting off air

Image 5. Pressure gauge

Drive link thickness

- 1 Loosen the locking knob (See *Bild 6 Pos 4 Locking knob, chain holder*) on the underside of the chain holder.
- 2 Set the correct value using the adjustment knob (See *Bild 6 Pos 3 Setting drive link thickness*).
- 3 Increase or decrease the distance between the chain rail plates with the gap setting knobs (See *Bild 6 Pos 1 Gap setting knob*), so that the chain runs easily when fed.
- 4 Lock the setting with the locking knob (See *Bild 6 Pos 4 Locking knob, chain holder*) on the underside of the chain holder.

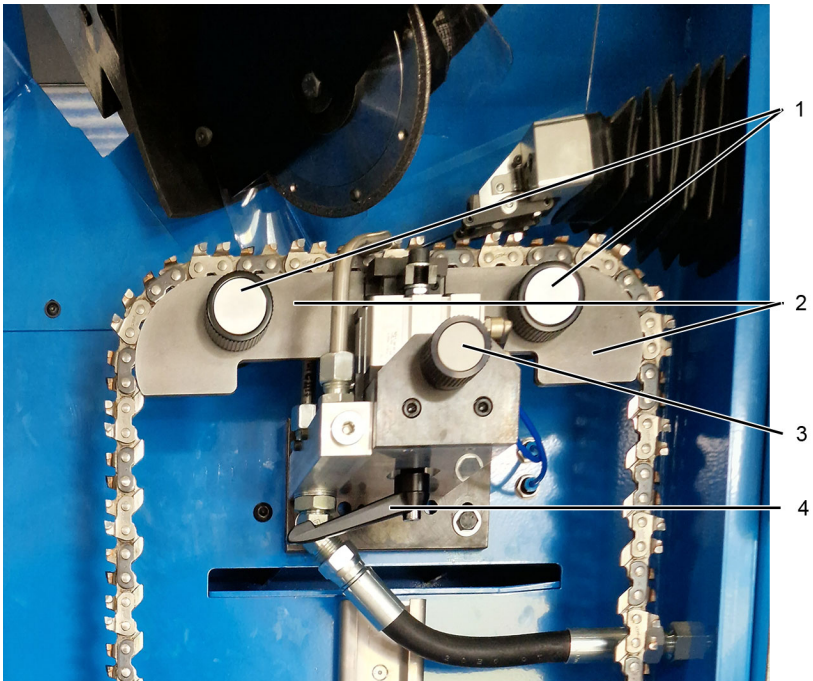

- | | | | |
|---|-------------------|---|------------------------------|
| 1 | Gap setting knob | 3 | Setting drive link thickness |
| 2 | Chain rail plates | 4 | Locking knob, chain holder |

Image 6. Chain holder Locking knob

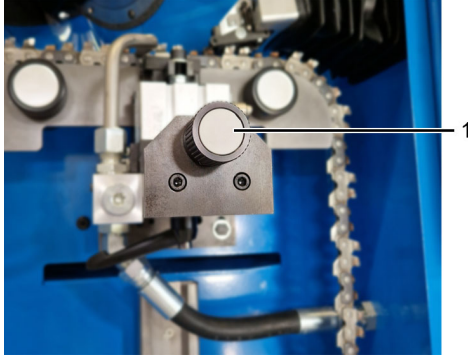

- 1 Setting drive link thickness

Image 7. Setting - drive link thickness

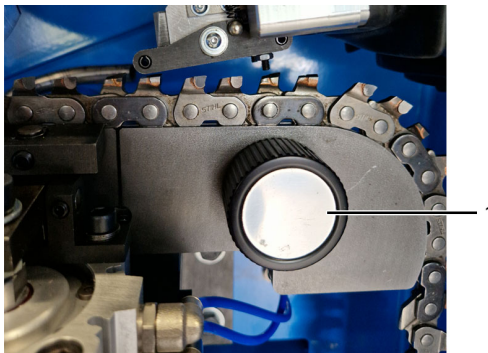

- 1 Gap setting knob

Image 8. Gap setting

Setting the pitch

- 1 Turn off the compressed air.
- 2 Loosen the locking knob on the top of the setting rail. (See *Bild 9*)
- 3 Slide the holder to the correct value on the scale.
- 4 Lock the settings with the locking knob.
- 5 Check that the forward feeding is correct for the chain in question. This can easily be done using **step operation**.



Image 9. Setting rail – pitch

Feed setting

The settings usually only need to be adjusted when changing the chain type. Power and compressed air must be turned on and the correct grinding wheel must be mounted.

(See *Tabell sida 2*)

- 1 Place the chain in the chain holder's groove and hang on the chain weight if necessary.
- 2 Move the chain's cutting tooth underneath the feed unit's sensor arms. You can press down the feeder to make sure that the correct sensor arm is touched. (See *Bild 10 and 11 Adjusting distance*)
- 3 Go to the chain adjustment page. Press and hold the button on the touch display for setting the tooth lifting cylinder (See *Bild 24 sida 24*) and simultaneously turn the knob for adjusting the lifting cylinder (See *Bild 4 Pos 4 Speed control grinder sida 8*)

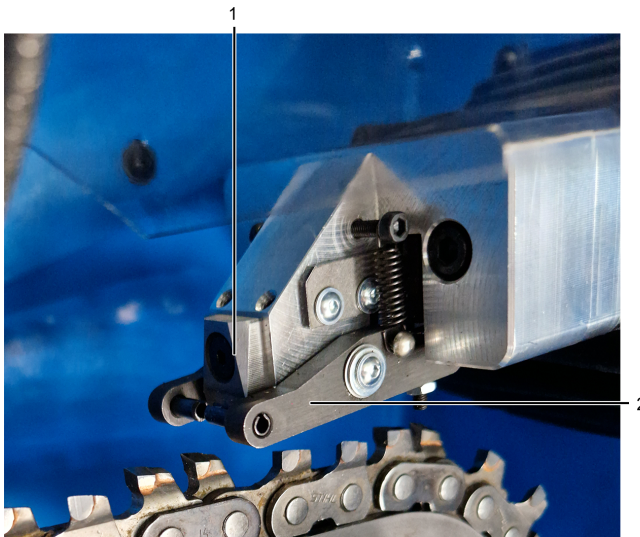

1 Feeder

2 Sensor arm

Image 10. Feeder unit

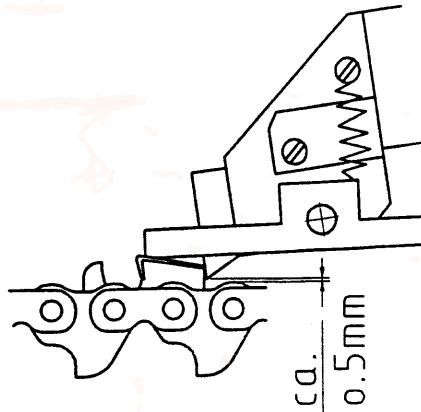

Image 11. Adjusting distance

Grinding depth adjustment

Anm

Adjustment that is normally performed after completed Feed setting.

- 1 After feed setting has been performed (See section *Feed setting* sida 14), the correct grinding depth needs to be checked.
- 2 On the chain adjustment page on the display, press the “Grinder down” button (See *Bild 24* sida 24) and then turn the knob to adjust the grinding depth (See *Bild 4* sida 8)
- 3 Test your setting by using the “Start” function button for chain setting (See *Bild 24* sida 24): press and hold the “Start” button on the display, which will cause the machine to start the grinding motor and lower the grinding unit as long as the button is pressed.

Setting the grinding angle α

Set the grinding angle using the knob next to the scale. (See *Bild 12*)

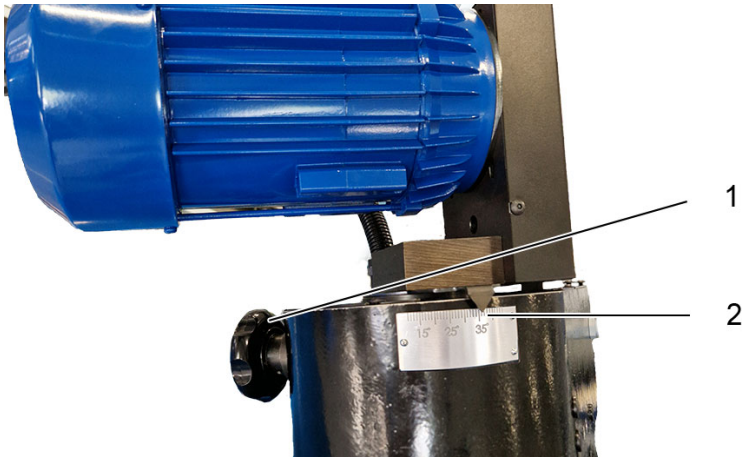

- 1 Adjustment knob for grinding angle α 2 Scale, grinding angle α

Image 12. Setting grinding angle scale α

Main screen

Main screen touch display

Initial page



Läs manual före användning!

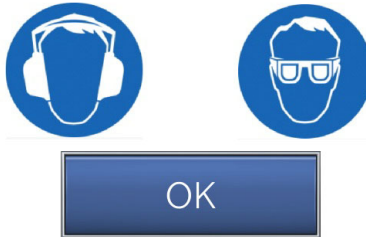
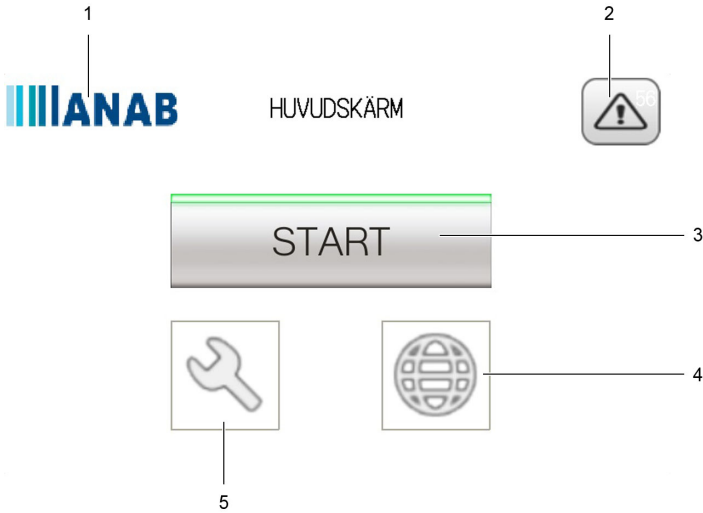

Image 13. Initial page at start-up

Start page



- 1 Contact page
- 2 Alarm page
- 3 Grinding

- 4 Language setting
- 5 Machine setting

Image 14. Main screen touch display

Contact page



Image 15. Contact information

If you have any questions about the machine, you can find all the contact information under the contact page.

Grinding page



- | | | | |
|---|-------------------|---|---|
| 1 | Home | 4 | Alarm triangle (only if alarms are present) |
| 2 | Grinding settings | 5 | Number of teeth |
| 3 | Chain setting | | |

Image 16. Grinding page

Setting the number of teeth

- 1 Press the figures behind the Counter (See *Bild 16*), after which you will be taken to the submenu for setting the number of teeth.
- 2 Enter the number of teeth for the chain that is to be sharpened.

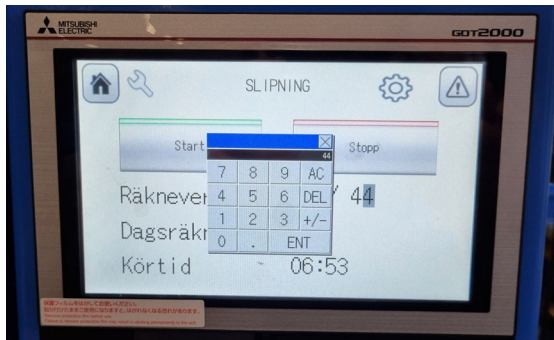
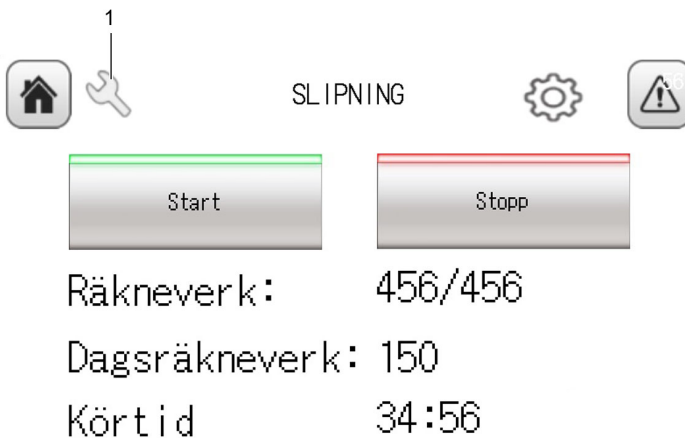

Image 17. Setting Number of teeth

- 3 Confirm selection with ENT.

Grinding settings

- 1 Go to the Grinding page, then press the settings button as shown below.



- 1 Machine setting

Image 18. Settings button

Press the relevant function's figure to change the image to perform setting.

MASKININSTÄLLNINGAR

Urslipningstid 5,5 s — 1

Hastighet börvärde: 55 m/s — 2



- 1 Grinding duration
- 2 Motor speed
- 3 Previous page

Image 19. Grinding setting, chain

Setting grinding duration

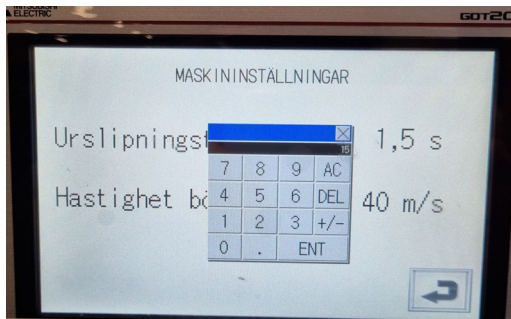

Image 20. Grinding duration setting

- 1 Press setting for grinding duration.
- 2 Enter the value for the selected parameter.
- 3 Confirm selection with ENT.

Anm

Grinding duration indicates how long the grinding wheel will be in the bottom position against the chain.

Motor speed

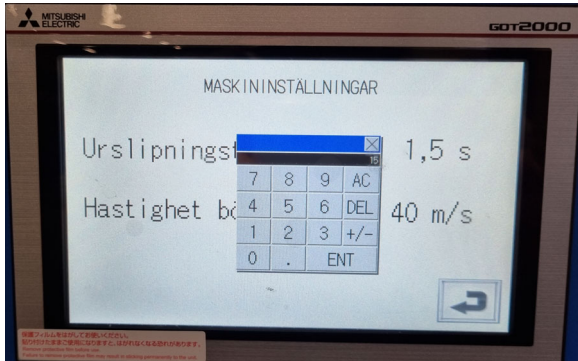

Image 21. Input - motor speed

- 1 Press setting for motor speed.
- 2 Enter the value for the selected parameter.
- 3 Confirm selection with ENT.

Chain setting

Chain setting - Step 1

After the chain has been positioned correctly (see Figure 11 *Adjusting distance* sida 15).

- 1 Press the “Feeder out” button according to Figure 22 *Chain setting - Step 1*. The machine then feeds one tooth forward before waiting.
- 2 Set the position with the knob for setting the grinding quantity (see Figure 4 *Operating panel* sida 8).

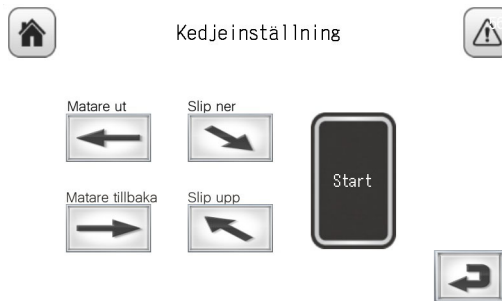

Image 22. Chain setting - Step 1

Chain setting - Step 2

- 1 Press the “Feeder back” button according to Figure 23 *Chain setting - Step 2*. The machine then locks the chain and goes back with the feeder so that you can make further settings.

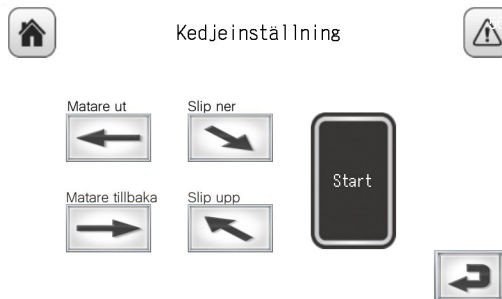

Image 23. Chain setting - Step 2

Chain setting - Step 3

There are two options here. See Figure 24 *Chain setting - Step 3*.

Using the “Grinder down” button, lower the grinding unit to make it possible to check the depth setting safely (See Figure 4 *Operating panel* sida 8).

The “Start” button is a touch-sensitive button. As long as it is held in, the machine will start the grinding motor and lower the grinding unit to the chain according to the previous setting; when the button is released, the machine will stop the motor and return the grinding unit to the normal position.

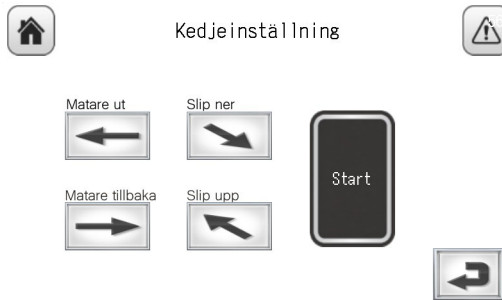

Image 24. Chain setting - Step 3

Chain setting - Step 4

Using the “Grinder up” button, the grinding unit is raised back to the normal position.



Image 25. Chain setting - Step 4

Machine settings

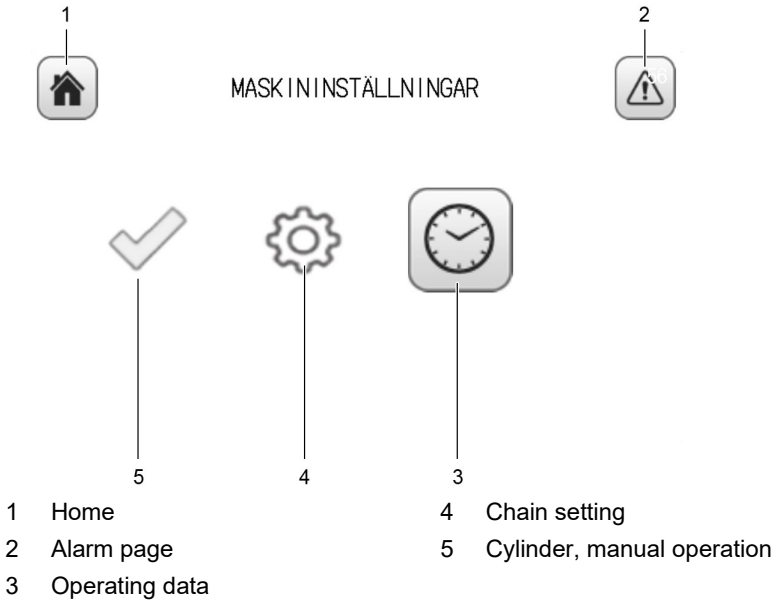

Image 26. Machine settings

Cylinder, manual operation



Image 27. Setting for manual operation

Anm

Button lights up Green to indicate whether the sensor is active/working. If the button does not light up, this indicates that the sensor is most likely out of order or incorrectly positioned.

Operating data



Image 28. Total operating time

Language setting



Image 29. Language selection

Anm

Press the desired language to confirm your selection.

Alarm page

Alarm, grinding

Occurred	Message	Checked
22/10/20 09:39	Ingen tand vid första matning	09:39
22/10/20 09:39	Matare ej i ute-läge	09:39
22/10/20 09:39	Slip i fel position	09:39
22/10/20 09:39	För lång tid i sekvenssteg för slip	09:39
22/10/20 09:39	Dubbla tänder indikerade	09:39
22/10/20 09:39	Andra försök dubbeltand	09:39
22/10/20 09:39	Ingen signal yttre tandsensor	09:39
22/10/20 09:39	Ingen signal yttre vridsensor	09:39
22/10/20 09:39	Ingen signal inre vridsensor	09:39
22/10/20 09:39	Ingen signal övre slipsensor	09:39
22/10/20 09:39	Ingen signal nedre slipsensor	09:39
22/10/20 09:39	Frekvensomriktare felande	09:39
22/10/20 09:39	PLC felande	09:39

Delete
Delete All
Check All



1 Previous page

2 Alarm acknowledgement

Image 30. Menu buttons, touch display

Maintenance

The machine is designed for long-term, safe operation without the need for special servicing. However, for preventive purposes, some elements should be checked regularly.

Safety

During all forms of maintenance, the **machine's power supply** and **compressed air** must always **be turned off** to eliminate any unnecessary accident risks. During troubleshooting, etc., measures should be taken to prevent accidental activation of the machine.

Daily

- Clean the sensor arms *Bild 31* on the feeder unit
- Clean the chain holder, the “chain rail”, to prevent inadequate clamping.
- Use a cloth or a small brush to clean.
- Avoid cleaning with compressed air as grinding particles can spread into the machine.

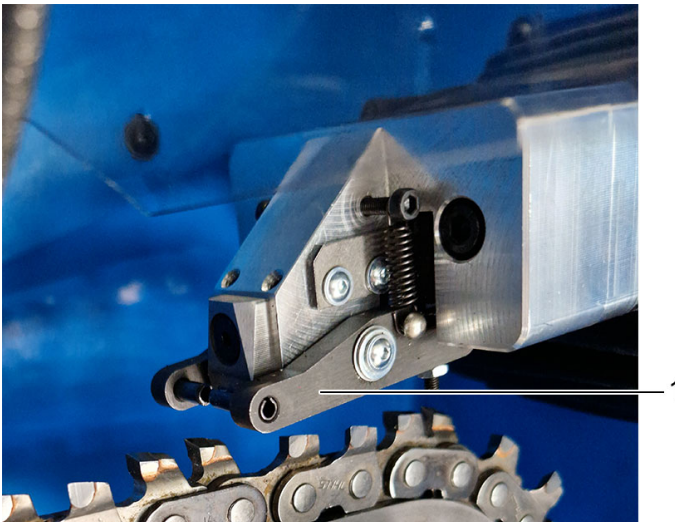

1 Sensor arm

Image 31. Sensor arm on feeder unit

Adjusting the air pressure

- 1 Increasing the pressure: Lift the plastic cover on the pressure regulator and turn clockwise until the gauge shows the correct pressure. (See *Bild 32*)
- 2 Decreasing the pressure: Turn anticlockwise and reduce to just below the desired pressure, then increase to the desired pressure.

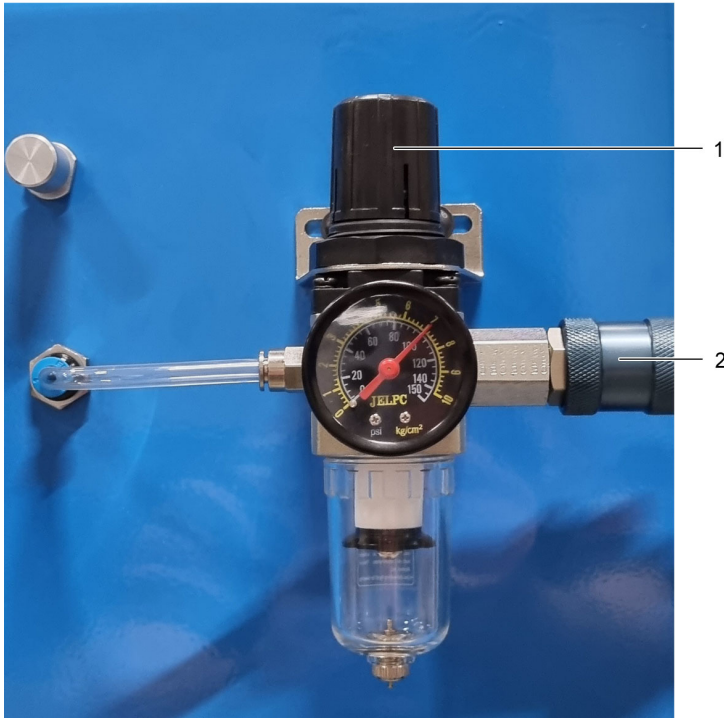

1 Air pressure knob

2 Air shut-off valve

Image 32. Pressure gauge

Anm

Recommended working pressure is approx. 6 bar.

If necessary, check/clean compressed air

- Empty the water separator on the pressure-reducing valve. (Loosen by turning the glass cup clockwise)
- Clean the filter. (Mounted in the glass separator)
- Wash the filter with spirits or similar.
- Then blow clean from the inside out and allow to dry.

OBS

The glass cup (container) must be cleaned in warm water with dishwashing liquid or regular detergent for household use. Solvents such as acetone, benzene and some alcohols may dissolve the plastic. If you are in doubt, check with ANAB.



- 1 Filter in glass cup

Image 33. Glass cup with filter

Cleaning machine

- 1 Clean the mating surface between the sensor arms and the microswitches. Use cleaning spray (CRC Bräkleen is recommended) and gently blow clean with compressed air. (See *Bild 34*)
- 2 Clean the entire machine.
- 3 Check electrical connections. Check *Belt tensioning* sida 33, motor and grinding wheel.

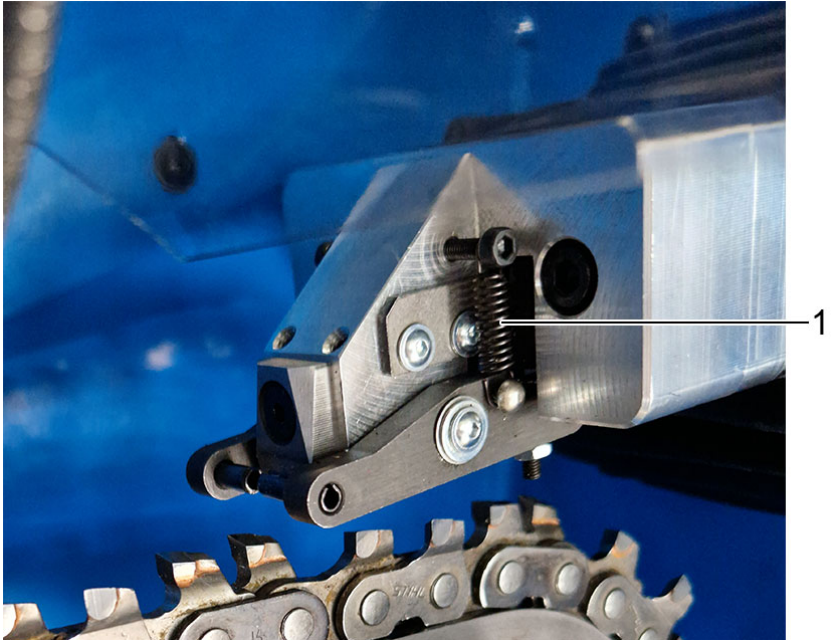

- 1 Microswitch

Image 34. Microswitch on sensor arm

Changing the grinding wheel

- 1 Turn off the power supply to the machine and make certain that it cannot be activated accidentally.
- 2 Loosen the screws for the cover and remove it.
- 3 Hold the grinding wheel firmly with one hand and loosen the centre bolt (normal right thread) with a 13 mm spanner. (See *Bild 35*)
- 4 Replace the wheel, hold with your hand and tighten the bolt to a torque of at least 40 Nm.
- 5 Refit the cover.



Image 35. Changing the grinding wheel

Anm

For the best grinding results, only use original ANAB grinding wheels.

Belt tensioning

- 1 Turn off the power supply to the machine and make certain that it cannot be activated accidentally.
- 2 Remove the motor cover.
- 3 Ease off the four hex screws securing the motor.
- 4 Under the motor, use a screwdriver or similar to stretch the belt. (See *Bild 36*)

OBS

Do not stretch too much. It must be possible to push the belt in approximately 10 mm in the middle.

- 5 Retighten the screws on the motor.
- 6 Refit the protective cover.

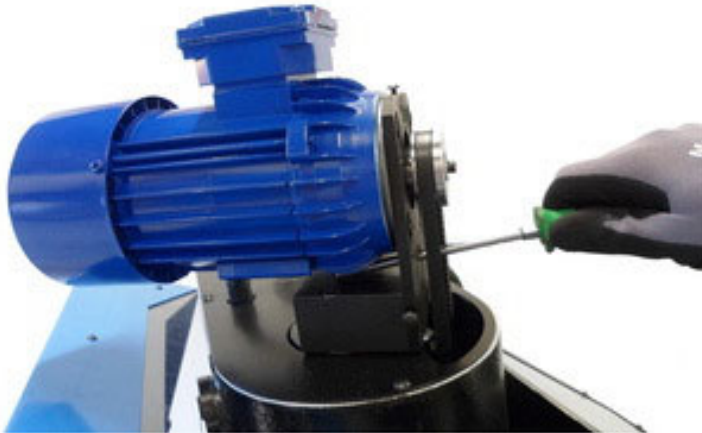

Image 36. Belt tensioning

OBS

The belt tension should be checked and adjusted if necessary after approx. 20 hours of operation.

Replacing the drive belt

- 1 Turn off the power supply to the machine and make certain that it cannot be activated accidentally.
- 2 Remove the motor and grinding head covers. Loosen the locking knob with an Allen key.
- 3 Loosen the hex screws securing the motor and unscrew the set screw under the motor.
- 4 Change the belt. Preferably use an original belt from ANAB.
- 5 Tension the belt (refer to the *Belt tensioning* section). Refit the covers, locking knob and screws.

Close-up images

Feeder unit linear control

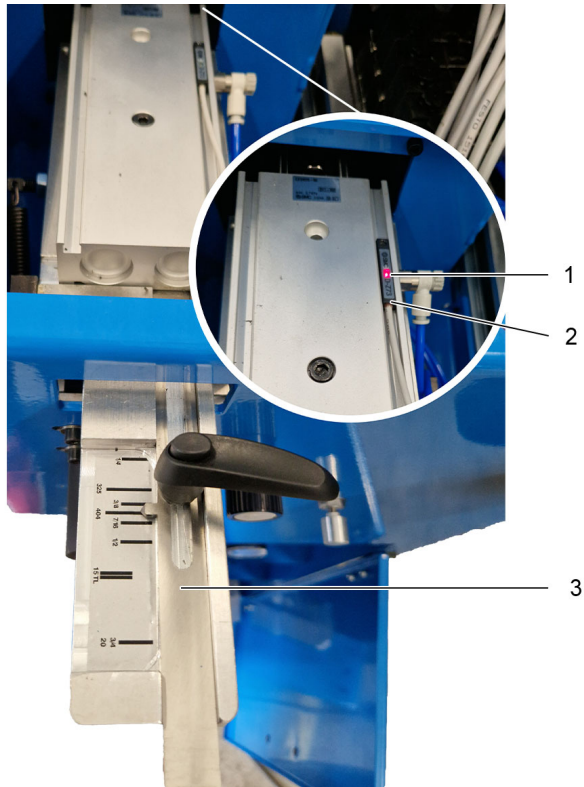

- 1 LED
- 2 Forward feeding sensor
FeederOut
- 3 Pitch setting unit

Image 37. Linear control

Grinding wheel lifting cylinder

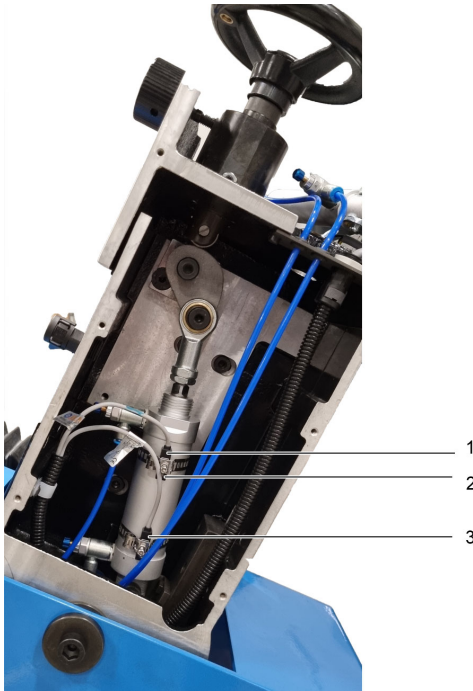

- | | | | |
|---|-----------------------------------|---|-------------------------------------|
| 1 | Limit position sensor, Grinder up | 3 | Limit position sensor, Grinder down |
| 2 | LED | | |

Image 38. Lifting cylinder

Swivel cylinder

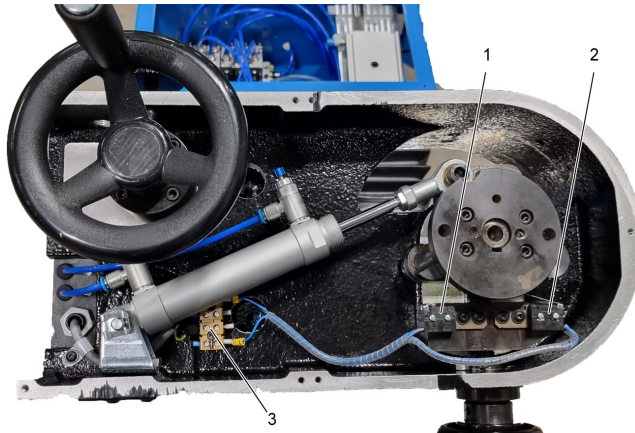

- 1 Left microswitch, Grinder Right
- 2 Right microswitch, Grinder Left
- 3 Terminal block

Image 39. Swivel cylinder

Connections

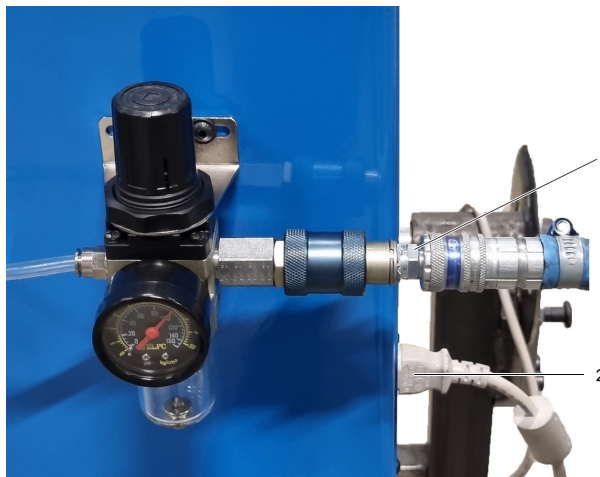

- 1 Compressed air connection
- 2 Power supply

Image 40. Connections

Troubleshooting

Problem solving

The machine does not start

Turn the machine off at the switch (*Bild 4 sida 8*) and turn on again. (This resets the electronics)

Motor guard triggered

Look for the fault and reset the motor guard.

Sensor arms do not rise/both sensor arms rise

- Chain fault or mechanical fault that has worn out the chain rail. Not enough play between the arms
- Also check the microswitches at the sensor arms.

Alarm from the frequency inverter

- Is the correct grinding wheel on the **Settings page** selected?
- Turn off the power supply for the machine with the main switch (*Bild 4 sida 8*) and then turn it on again after a few seconds. (The frequency inverter is reset again)

